



www.jlh-spain.com

N.I.F. B-59.148.007

CATÁLOGO · CATALOGUE
ABRIL · APRIL · AVRIL
2024



www.jlh-spain.com

Made in Spain 



Tubo

Tube / Tuyau

CARACTERÍSTICAS TÉCNICAS	TECHNICAL CHARACTERISTICS	SPÉCIFICATIONS TECHNIQUES
<ul style="list-style-type: none"> Tubo EPDM sanitario. Reforzado con trenza acero inoxidable AISI 304. 	<ul style="list-style-type: none"> EPDM Sanitary hose. Stainless Steel knitting AISI 304. 	<ul style="list-style-type: none"> Tuyau EPDM sanitaire Renforcé avec tresse d'acier inox AISI 304

Tubo reforzado con hilo acero INOXIDABLE

INOX braided hose / Tuyau renforcé avec fil d'acier inox.



DN8	M13	8.5x12 mm	2.55€
DN13	M19	13x19 mm	5.40€
DN19	M26	19x26 mm	12.50€
DN25	M33	25x33 mm	15.60€
DN30	M40	30x40 mm	55.00€
DN40	M50	40x55 mm	70.00€
DN50	M60	50x65 mm	82.00€

Accesorios

Fittings / Raccords

Casquillo Acero Inoxidable AISI 304

S S 304 Neck
Embout d'acier inox
AISI 304



DN8	C13	0.11€
DN13	C19	0.21€
DN19	C26	1.05€
DN25	C33	1.49€
DN30	C40	4.60€
DN40	C50	5.50€
DN50	C60	6.60€

Nipple latón

Brass Nipple
Mamelon fileté en laiton



DN8	13N38	0.30€
DN8	13N12	0.37€
DN13	19N12	0.53€
DN13	19N34	0.59€
DN25	26N34	1.36€
DN30	33N1	2.15€
DN35	40N114	6.64€
DN40	50N112	9.05€
DN50	60N2	15.10€

Tuerca latón

Brass Nut
Écrou en laiton



DN8	13T38	0.40€
DN8	13T12	0.61€
DN13	19T12	0.65€
DN13	19T34	0.97€
DN25	26T34	1.25€
DN30	33T1	2.00€
DN35	40T114	5.48€
DN40	50T112	6.30€
DN50	60T2	10.35€

Machón

Brass Raccord
Raccord Mâle en laiton



DN8	13R38	0.77€
DN8	13R12	0.90€
DN13	19R12	1.13€
DN13	19R34	1.78€
DN25	26R34	2.29€
DN30	33R1	4.12€
DN35	40R114	11.05€
DN40	50R112	15.36€
DN50	60R2	22.36€

Codo latón

Brass bend angles
Raccord à coudé en laiton



DN8	13C38	1.22€
DN8	13C12	1.31€
DN13	19C12	1.91€
DN13	19C34	1.90€
DN19	26C34	3.16€
DN25	33C1	4.24€

Nipple monomando grifería

Mixer tap nipple
Mamelon fileté pour robinetterie



DN8	13BC10	L 18 mm	0.75€
DN8	13BL10	L 35 mm	0.95€
DN8	13BSL10	L 75 mm	2.25€

Ref. 30 Cartuchos de cerámica para monomando

Ceramic mixer cartridges

APPLICABLE STANDARDS REFERENCE EN200

Cartouches ceramiques pour robinet monocommande



ø 35

Bag
30CM35 3.50€



ø 35

Con distribuidor
With distributor
Bag
30CM35C 3.50€



ø 40

Bag
30CM40 3.50€



ø 40

Con distribuidor
With distributor
Bag
30CM40C 3.50€

Conexiones Connection for drinking water

Flexibles de raccordement

Accesorios Sanitarios JLH SL establece un Sistema de Gestión que ha sido auditado y encontrado conforme con los requisitos de la norma NORMA ISO 9001:2015 Además disponemos de la aprobación de las marcas de calidad de más de 10 países, como cUPC, NSF61, NSF372, CSA, WRAS, DVGW, KTW, W270, ACS, QB, KIWA, SINTEF, AENOR, VA, RISE, STF, WATERMARK, AGA, etc.

Accesorios Sanitarios JLH SL establishes a Management System that has been audited and found to comply with the requirements of the standard ISO 9001:2015 STANDARD We also have the approval of quality marks from more than 10 countries, such as cUPC, NSF61, NSF372, CSA, WRAS, DVGW, KTW, W270, ACS, QB, KIWA, SINTEF, AENOR, VA, RISE, STF, WATERMARK, AGA, etc.



	Ø Interior / Inner	Ø Exterior / Outer	Ø Paso / Inside passage	Caudal nominal a 3 bar / Flow	Radio mínimo curvatura / Minimum bending radius	Presión servicio / Working pressure	Temperatura / Working temperature	H ₂ O potable
DN8	8,5mm	12mm	6mm	28 lit/min	30mm	10 bar	90°C	
DN13	12mm	17mm	10mm	70 lit/min	45mm			
DN19	19mm	26mm	15mm	120 lit/min	70mm			
DN25	25mm	33mm	20mm <td 200 lit/min	100mm				
DN30	30mm	42mm	25mm	400 lit/min	190mm			
DN40	40mm	52mm	32mm	700 lit/min	230mm			
DN50	50mm	62mm	40mm	1050 lit/min	300mm			

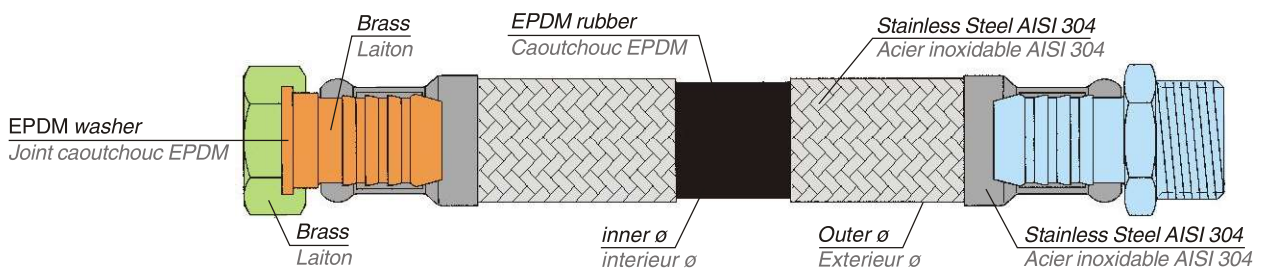

UTILIZACIÓN / USAGE

CORRECTO / CORRECT

INCORRECTO / INCORRECT

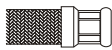

En ninguna circunstancia debe instalarse una conexión flexible con una campana sin engatillar.
Under no circumstance a flexible water connection must be installed without having previously stapled the neck.
En aucun cas on doit s'installer un flexible de raccordement sans serrure.

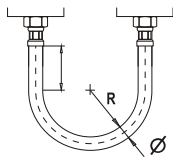
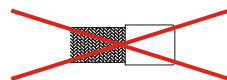

Respetar la curvatura natural del flexible y prever una longitud suficiente $R \geq 3$ veces el \emptyset (radio mínimo de curvatura).
Keep the natural curve of the flexible connection and prevent enough length for the installation. $R \geq 3$ times of the \emptyset (minimum curve radius)
Respecter la courbure naturelle du flexible et prévoir une longueur suffisant $R \geq 3$ fois le diamètre (minimum de rayon de courbure)

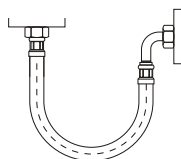
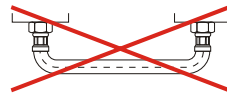

Respetar el radio de curvatura mínimo y utilizar codos cuando sea posible.
Keep the minimum curve radius and make use of bend angles when it is possible.
Respecter le rayon minimum de courbure et utiliser raccords coudeux si possible

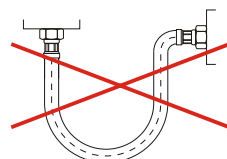

Longitud standard

Standard lengths
Longueur standard

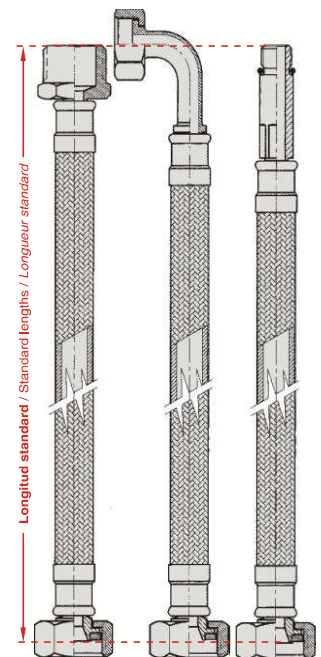

Conexiones

Connection for drinking water

Flexibles de raccordement

DN8



JLH 12



APPLICABLE STANDARDS REFERENCE UNE-EN 13618

M1/2	H1/2	M3/8	H3/8	M3/8	H1/2	M1/2	H3/8	H1/2	H1/2
15 cm 0115M12H12 2.26€	15 cm 0115H12H12 2.21€	10 cm 0110M38H38 1.75€	10 cm 0110H38H38 1.67€	15 cm 0115M38H12 2.11€	15 cm 0115H12H38 2.00€	15 cm 0115M12H38 2.05€	15 cm 0115H12H78 2.60€	15 cm 0115M12H12 2.26€	15 cm 0115H12H12 2.21€
20 cm 0120M12H12 2.38€	20 cm 0120H12H12 2.33€	15 cm 0115M38H38 1.87€	15 cm 0115H38H38 1.79€	20 cm 0120M38H12 2.23€	20 cm 0120H12H38 2.12€	20 cm 0120M12H38 2.17€	20 cm 0120H12H78 2.60€	20 cm 0120M12H12 2.38€	20 cm 0120H12H12 2.33€
25 cm 0125M12H12 2.50€	25 cm 0125H12H12 2.45€	20 cm 0120M38H38 1.99€	20 cm 0120H38H38 1.91€	25 cm 0125M38H12 2.35€	25 cm 0125H12H38 2.24€	25 cm 0125M12H38 2.29€	25 cm 0125H12H78 2.60€	25 cm 0125M12H12 2.50€	25 cm 0125H12H12 2.45€
30 cm 0130M12H12 2.62€	30 cm 0130H12H12 2.57€	25 cm 0125M38H38 2.11€	25 cm 0125H38H38 2.03€	30 cm 0130M38H12 2.47€	30 cm 0130H12H38 2.36€	30 cm 0130M12H38 2.41€	30 cm 0130H12H78 2.60€	30 cm 0130M12H12 2.62€	30 cm 0130H12H12 2.57€
35 cm 0135M12H12 2.74€	35 cm 0135H12H12 2.69€	30 cm 0130M38H38 2.23€	30 cm 0130H38H38 2.15€	35 cm 0135M38H12 2.59€	35 cm 0135H12H38 2.48€	35 cm 0135M12H38 2.53€	35 cm 0135H12H78 2.60€	35 cm 0135M12H12 2.74€	35 cm 0135H12H12 2.69€
40 cm 0140M12H12 2.86€	40 cm 0140H12H12 2.81€	35 cm 0135M38H38 2.36€	35 cm 0135H38H38 2.27€	40 cm 0140M38H12 2.71€	40 cm 0140H12H38 2.60€	40 cm 0140M12H38 2.65€	40 cm 0140H12H78 2.60€	40 cm 0140M12H12 2.86€	40 cm 0140H12H12 2.81€
50 cm 0150M12H12 3.11€	50 cm 0150H12H12 3.05€	40 cm 0140M38H38 2.48€	40 cm 0140H38H38 2.39€	50 cm 0150M38H12 2.95€	50 cm 0150H12H38 2.84€	50 cm 0150M12H38 2.89€	50 cm 0150H12H78 2.60€	50 cm 0150M12H12 3.11€	50 cm 0150H12H12 3.05€
60 cm 0160M12H12 3.35€	60 cm 0160H12H12 3.29€	50 cm 0150M38H38 2.71€	50 cm 0150H38H38 2.63€	60 cm 0160M38H12 3.19€	60 cm 0160H12H38 3.08€	60 cm 0160M12H38 3.13€	60 cm 0160H12H78 2.60€	60 cm 0160M12H12 3.35€	60 cm 0160H12H12 3.29€
70 cm 0170M12H12 3.59€	70 cm 0170H12H12 3.53€	60 cm 0160M38H38 2.95€	60 cm 0160H38H38 2.87€		80 cm 0180H12H38 3.56€			70 cm 0170M12H12 3.59€	70 cm 0170H12H12 3.53€
80 cm 0180M12H12 3.85€	80 cm 0180H12H12 3.77€	70 cm 0170M38H38 3.19€	70 cm 0170H38H38 3.11€		100 cm 01100H12H38 4.04€			80 cm 0180M12H12 3.85€	80 cm 0180H12H12 3.77€
90 cm 0190M12H12 4.08€	90 cm 0190H12H12 4.01€	80 cm 0180M38H38 3.43€	80 cm 0180H38H38 3.35€					90 cm 0190M12H12 4.08€	90 cm 0190H12H12 4.01€
100 cm 01100M12H12 4.32€	100 cm 01100H12H12 4.25€	100 cm 01100M38H38 3.91€	100 cm 01100H38H38 3.83€					100 cm 01100M12H12 4.32€	100 cm 01100H12H12 4.25€

H3/8	H3/8
10 cm 0110H38H38 1.67€	10 cm 0110H38H38 1.67€
15 cm 0115H38H38 1.79€	15 cm 0115H38H38 1.79€
20 cm 0120H38H38 1.91€	20 cm 0120H38H38 1.91€
25 cm 0125H38H38 2.03€	25 cm 0125H38H38 2.03€
30 cm 0130H38H38 2.15€	30 cm 0130H38H38 2.15€
35 cm 0135H38H38 2.27€	35 cm 0135H38H38 2.27€
40 cm 0140H38H38 2.39€	40 cm 0140H38H38 2.39€
50 cm 0150H38H38 2.63€	50 cm 0150H38H38 2.63€
60 cm 0160H38H38 2.87€	60 cm 0160H38H38 2.87€
70 cm 0170H38H38 3.11€	70 cm 0170H38H38 3.11€
80 cm 0180H38H38 3.35€	80 cm 0180H38H38 3.35€
100 cm 01100H38H38 3.83€	100 cm 01100H38H38 3.83€

H1/2	H3/8
15 cm 0115H12H38 2.00€	15 cm 0115H12H38 2.00€
20 cm 0120H12H38 2.12€	20 cm 0120H12H38 2.12€
25 cm 0125H12H38 2.24€	25 cm 0125H12H38 2.24€
30 cm 0130H12H38 2.36€	30 cm 0130H12H38 2.36€
35 cm 0135H12H38 2.48€	35 cm 0135H12H38 2.48€
40 cm 0140H12H38 2.60€	40 cm 0140H12H38 2.60€
50 cm 0150H12H38 2.84€	50 cm 0150H12H38 2.84€
60 cm 0160H12H38 3.08€	60 cm 0160H12H38 3.08€
80 cm 0180H12H38 3.56€	80 cm 0180H12H38 3.56€
100 cm 01100H12H38 4.04€	100 cm 01100H12H38 4.04€

H1/2	C1/2
30 cm 0130C12H12 3.83€	30 cm 0130C12H12 3.83€
40 cm 0140C12H12 4.07€	40 cm 0140C12H12 4.07€
50 cm 0150C12H12 4.31€	50 cm 0150C12H12 4.31€
100 cm 01100C12H12 5.51€	100 cm 01100C12H12 5.51€

H3/8	C3/8
30 cm 0130C38H38 3.45€	30 cm 0130C38H38 3.45€
40 cm 0140C38H38 3.69€	40 cm 0140C38H38 3.69€
50 cm 0150C38H38 3.93€	50 cm 0150C38H38 3.93€

H1/2	H7/8
35 cm 0135H12H78 2.60€	35 cm 0135H12H78 2.60€
60 cm 0160H12H78 3.80€	60 cm 0160H12H78 3.80€

H1/2	H5/8
35 cm 0135H12H58 3.60€	35 cm 0135H12H58 3.60€
60 cm 0160H12H58 4.20€	60 cm 0160H12H58 4.20€

Colgador expositor Connection hanger

PET12 Conexión ø12 0.12€
PET17 Conexión ø17 0.13€



DN8



JLH GRIFERÍA

APPLICABLE STANDARDS REFERENCE UNE-EN 13618

M10x100/L18 mm	H3/8
30 cm 03305338(2) 4.21€	30 cm 03305338(2) 4.21€
35 cm 03355338(2) 4.44€	35 cm 03355338(2) 4.44€
40 cm 03405338(2) 4.67€	40 cm 03405338(2) 4.67€
50 cm 03505338(2) 5.14€	50 cm 03505338(2) 5.14€
60 cm 03605338(2) 5.60€	60 cm 03605338(2) 5.60€
80 cm 03805338(2) 6.65€	80 cm 03805338(2) 6.65€
100 cm 031005338(2) 7.45€	100 cm 031005338(2) 7.45€

M10x100/L18 mm	H1/2
30 cm 03305312(2) 4.53€	30 cm 03305312(2) 4.53€
35 cm 03355312(2) 4.76€	35 cm 03355312(2) 4.76€
40 cm 03405312(2) 4.99€	40 cm 03405312(2) 4.99€
50 cm 03505312(2) 5.45€	50 cm 03505312(2) 5.45€
60 cm 03605312(2) 5.92€	60 cm 03605312(2) 5.92€

M10x1/L75 mm	H3/8
30 cm 03307538 3.60€	30 cm 03307538 3.60€
35 cm 03357538 3.72€	35 cm 03357538 3.72€
40 cm 03407538 3.84€	40 cm 03407538 3.84€
50 cm 03507538 4.08€	50 cm 03507538 4.08€

DN13 JLH SUPER

APPLICABLE STANDARDS REFERENCE UNE-EN 13618



M1/2		H1/2		M1/2		H3/4		M3/4		H3/4		M3/4		H1/2		H1/2		H1/2		
20 cm	0220M12H12	3.67€		20 cm	0220M12H34	4.07€		20 cm	0220M34H34	4.61€		20 cm	0220M34H12	4.26€		20 cm	0220H12H12	3.57€		
25 cm	0225M12H12	3.91€		25 cm	0225M12H34	4.31€		25 cm	0225M34H34	4.85€		25 cm	0225M34H12	4.50€		25 cm	0225H12H12	3.81€		
30 cm	0230M12H12	4.15€		30 cm	0230M12H34	4.55€		30 cm	0230M34H34	5.09€		30 cm	0230M34H12	4.74€		30 cm	0230H12H12	4.05€		
35 cm	0235M12H12	4.39€		35 cm	0235M12H34	4.79€		35 cm	0235M34H34	5.33€		35 cm	0235M34H12	4.98€		35 cm	0235H12H12	4.29€		
40 cm	0240M12H12	4.63€		40 cm	0240M12H34	5.03€		40 cm	0240M34H34	5.57€		40 cm	0240M34H12	5.22€		40 cm	0240H12H12	4.53€		
50 cm	0250M12H12	5.11€		50 cm	0250M12H34	5.51€		50 cm	0250M34H34	6.05€		50 cm	0250M34H12	5.70€		50 cm	0250H12H12	5.01€		
60 cm	0260M12H12	5.59€		60 cm	0260M12H34	5.90€		60 cm	0260M34H34	6.53€		60 cm	0260M34H12	6.18€		60 cm	0260H12H12	5.49€		
70 cm	0270M12H12	6.07€						100 cm	02100M34H34	8.45€						70 cm	0270H12H12	5.97€		
80 cm	0280M12H12	6.55€														80 cm	0280H12H12	6.45€		
100 cm	02100M12H12	7.51€														100 cm	02100H12H12	7.41€		
150 cm	02150M12H12	9.91€														150 cm	02150H12H12	9.81€		

H1/2		H3/4		H3/4		H3/4		H1/2		C1/2		H3/4		C3/4	
20 cm	0220H12H34	3.98€		20 cm	0220H34H34	4.38€		30 cm	0230C12H12	5.11€		30 cm	0230C34H34	9.50€	
25 cm	0225H12H34	4.22€		25 cm	0225H34H34	4.62€		40 cm	0240C12H12	5.59€		40 cm	0240C34H34	9.98€	
30 cm	0230H12H34	4.46€		30 cm	0230H34H34	4.86€		50 cm	0250C12H12	6.07€		50 cm	0250C34H34	10.50€	
35 cm	0235H12H34	4.70€		35 cm	0235H34H34	5.10€		60 cm	0260C12H12	6.55€		60 cm	0260C34H34	11.00€	
40 cm	0240H12H34	4.94€		40 cm	0240H34H34	5.34€		100 cm	02100C12H12	10.50€		100 cm	02100C34H34	13.00€	
50 cm	0250H12H34	5.42€		50 cm	0250H34H34	5.82€						150 cm	02150C34H34	15.50€	
60 cm	0260H12H34	5.90€		60 cm	0260H34H34	6.30€						200 cm	02200C34H34	18.00€	

DN19

APPLICABLE STANDARDS REFERENCE UNE-EN 13618

M3/4		H3/4		H3/4		H3/4		H3/4		H3/4	
30 cm	0630MH34	11.40€		60 cm	0660MH34	15.03€		30 cm	0630HH34	11.40€	
40 cm	0640MH34	12.60€		80 cm	0680MH34	17.45€		40 cm	0640HH34	12.60€	
50 cm	0650MH34	13.82€		100 cm	06100MH34	19.87€		50 cm	0650HH34	13.82€	
								60 cm	0660HH34	15.03€	
								80 cm	0680HH34	17.45€	
								100 cm	06100HH34	19.87€	

M1		H1		H1		H1		H1		H1	
30 cm	0630MH1	15.60€		60 cm	0660MH1	19.20€		30 cm	0630HH1	15.60€	
40 cm	0640MH1	16.80€		80 cm	0680MH1	21.65€		40 cm	0640HH1	16.80€	
50 cm	0650MH1	18.00€		100 cm	06100MH1	24.10€		50 cm	0650HH1	18.00€	
								60 cm	0660HH1	19.20€	
								80 cm	0680HH1	21.65€	
								100 cm	06100HH1	24.10€	

DN25 1 1/4"

M1 1/4		H1 1/4		H1 1/4		H1 1/4		H1 1/4		H1 1/4	
30 cm	0630MH114	34.00€		60 cm	0660MH114	39.10€		30 cm	0630HH114	34.00€	
40 cm	0640MH114	35.70€		80 cm	0680MH114	42.50€		40 cm	0640HH114	35.70€	
50 cm	0650MH114	37.40€		100 cm	06100MH114	45.90€		50 cm	0650HH114	37.40€	
								60 cm	0660HH114	39.10€	
								80 cm	0680HH114	42.50€	
								100 cm	06100HH114	45.90€	

Disponibles tubos / Available tubes of: DN40 - 1 1/2" y / and DN50 - 2"

Conexión trenzado POLÍMERO

Made in Spain 

Polymer braided connector connexion tressée POLYMÈRE

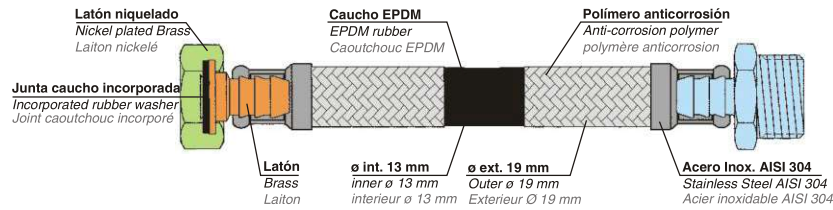

<ul style="list-style-type: none"> Alta resistencia a la corrosión Recomendable en zonas costeras, ambientes húmedos, etc. 	<ul style="list-style-type: none"> Corrosion resistant. It is specially recommended for coastal areas with high salt concentration, for moisture, etc. 	<ul style="list-style-type: none"> Résistant à la corrosion. Il est spécialement recommandé pour les zones côtières à forte concentration en sel, pour l'humidité, etc.
--	--	---

DN8 Conexión sanitaria

Connection for drinking water / Flexibles de raccordement inox

M1/2	H1/2	M3/8	H3/8	H1/2	H1/2	H3/8	H3/8	H1/2	H3/8
20 cm DN8M12H12P20 2.29€	20 cm DN8M38H38P20 1.94€	20 cm DN8H12H12P20 2.15€	20 cm DN8H38H38P20 1.90€	25 cm DN8M12H12P25 2.36€	25 cm DN8M38H38P25 2.01€	25 cm DN8H12H12P25 2.22€	25 cm DN8H38H38P25 1.97€	25 cm DN8M12H12P30 2.43€	25 cm DN8M12H38P20 2.08€
30 cm DN8M12H12P30 2.43€	30 cm DN8M38H38P30 2.08€	30 cm DN8H12H12P30 2.29€	30 cm DN8H38H38P30 2.04€	40 cm DN8M12H12P40 2.57€	40 cm DN8M38H38P40 2.22€	40 cm DN8H12H12P40 2.43€	40 cm DN8H38H38P40 2.18€	40 cm DN8M12H12P50 2.71€	40 cm DN8M12H38P30 2.18€
50 cm DN8M12H12P50 2.71€	50 cm DN8M38H38P50 2.36€	50 cm DN8H12H12P50 2.57€	50 cm DN8H38H38P50 2.32€	60 cm DN8M12H12P60 2.85€	60 cm DN8M38H38P60 2.50€	60 cm DN8H12H12P60 2.71€	60 cm DN8H38H38P60 2.46€	60 cm DN8M12H12P80 3.13€	60 cm DN8M12H38P40 2.32€
80 cm DN8M12H12P80 3.13€	80 cm DN8M38H38P80 2.78€	80 cm DN8H12H12P80 2.99€	80 cm DN8H38H38P80 2.75€	100 cm DN8M12H12P100 3.42€	100 cm DN8M38H38P100 3.06€	100 cm DN8H12H12P100 3.27€	100 cm DN8H38H38P100 3.03€	80 cm DN8M12H38P50 2.46€	80 cm DN8M12H38P60 2.61€
								100 cm DN8M12H38P80 2.89€	100 cm DN8M12H38P100 3.17€

DN8 Conexión grifería

Water connections for sanitary ware / Flexibles de raccordement pour robinetterie

M10x1/L18 mm	H3/8	M10x1/L35 mm	H3/8
35 cm DN81838P35 1.97€	35 cm DN83538P35 2.18€	40 cm DN81838P40 2.04€	40 cm DN83538P40 2.25€
50 cm DN81838P50 2.18€	50 cm DN83538P50 2.39€	60 cm DN81838P60 2.32€	60 cm DN83538P60 2.54€

DN13 Conexión SUPER

Water connections SUPER / Flexibles de raccordement SUPER

M1/2	H1/2	M3/4	H3/4	H1/2	H1/2	H3/4	H3/4
20 cm DN13M12H12P20 3.31€	20 cm DN13M34H34P20 4.47€	20 cm DN13H12H12P20 3.17€	20 cm DN13H34H34P20 4.19€	30 cm DN13M12H12P30 3.52€	30 cm DN13M34H34P30 4.68€	30 cm DN13H12H12P30 3.38€	30 cm DN13H34H34P30 4.40€
40 cm DN13M12H12P40 3.77€	40 cm DN13M34H34P40 4.93€	40 cm DN13H12H12P40 3.63€	40 cm DN13H34H34P40 4.65€	50 cm DN13M12H12P50 3.98€	50 cm DN13M34H34P50 5.14€	50 cm DN13H12H12P50 3.84€	50 cm DN13H34H34P50 4.86€
60 cm DN13M12H12P60 4.23€	60 cm DN13M34H34P60 5.39€	60 cm DN13H12H12P60 4.08€	60 cm DN13H34H34P60 5.11€	80 cm DN13M12H12P80 4.68€	80 cm DN13M34H34P80 5.85€	80 cm DN13H12H12P80 4.54€	80 cm DN13H34H34P80 5.56€
100 cm DN13M12H12P100 5.14€	100 cm DN13M34H34P100 6.30€	100 cm DN13H12H12P100 5.00€	100 cm DN13H34H34P100 6.02€				

Conexión GAS

Extensible GAS connection

Flexibles GAZ extensibles



Características técnicas

Fabricado íntegramente en acero inoxidable. Totalmente protegida la zona anular con plástico aislante amarillo o blanco de 0,5 mm de espesor que evita la corrosión por líquidos agresivos y evita la dispersión eléctrica. Extensible 75%. Tubo flexible de acero inoxidable, con conexiones para conducción de combustibles gaseosos a media presión, según norma 60.713/1.

Aplicaciones

Para la unión a instalaciones receptoras individuales fijas de aparatos de gas fijos o inmovilizados, que utilicen como combustible gases de la 1ª, 2ª y 3ª familia, alimentados a presiones no superiores a 0,5 Bars.

Characteristics

Made entirely from stainless steel. The circular section is completely protected by 0,5 mm thick, yellow or white plastic insulation to prevent corrosion by aggressive liquids and avoid electrical dispersion. 75% extendable. Flexible, extendable, stainless steel hose with connections for medium pressure gas conduction according to regulation 60.713/1.

Applications

Connection to individual, fixed or immobilised, gas appliances that use 1st, 2nd or 3rd family combustible gases at pressures of up to 0,4 Bar.

Spécifications

Fabriqué entièrement en acier inoxydable. Totalement protégé la partie annulaire avec plastique isolant jaune ou blanc de 0,5mm d'épaisseur pour éviter la corrosion de liquides agresivos en évitant la dispersion électrique. Extensible 75%. Tuyau flexible d'acier inoxydable avec raccords pour la conduction de combustibles gazeux a pression moyenne, selon réglementation 60.713/1.

Applications

Pour le raccordement à installations receptraires individuelles d'appareils gaz fixes ou immobilisés qu'utilisent comme combustible gaz des familles 1er, 2eme, et 3eme, alimentées à pressiones inferiores à 0,4 bar.

DN12/20

APPLICABLE STANDARDS REFERENCE 60.713/1

Available lengths / longueurs disponibles **cm**

20 a / to 34 cm 30 a / to 51 cm
50 a / to 85 cm 75 a / to 127 cm

H1/2 H1/2 DN12



20 a / to 34 cm 1520H12H12 10.50€
30 a / to 51 cm 1530H12H12 12.30€
50 a / to 85 cm 1550H12H12 15.70€
75 a / to 127 cm 1575H12H12 20.00€

M1/2 H1/2 DN12



20 a / to 34 cm 1520M12H12 9.30€
30 a / to 51 cm 1530M12H12 11.80€
50 a / to 85 cm 1550M12H12 15.40€
75 a / to 127 cm 1575M12H12 19.60€

H1/2 H3/4 DN12



20 a / to 34 cm 1520H12H34 12.55€
30 a / to 51 cm 1530H12H34 14.50€
50 a / to 85 cm 1550H12H34 18.10€

H3/4 H3/4 DN20



20 a / to 34 cm 1520H34H34 16.75€
30 a / to 51 cm 1530H34H34 20.45€
50 a / to 85 cm 1550H34H34 26.34€
75 a / to 127 cm 1575H34H34 34.55€

M3/4 H3/4 DN20



50 a / to 85 cm 1550M34H34 25.60€

KIT CONEXIONES FLEXIBLES PARA CALDERA

Flexible connection kit for builers

Según norma / According UNE 60713

Extensible / Stainless Steel



15KITGAS 52.90€

Tubo de gas con válvula de seguridad

Gas tube with safety valve

UNE EN 14800

CARACTERÍSTICAS TÉCNICAS

- Tubo coarrugado Acero Inox. AISI 304 reforzado con tuerca de hilo de Acero Inox. AISI 304 recubierto de PVC.
- Tuercas y casquillos de Acero Inox. AISI 304
- Juntas NBR
- Diámetro exterior: 20 mm
- Diámetro interior: 12 mm
- Diámetro de paso: 8 mm
- Caudal: >0,8m³/h
- Radio curvatura mínimo: no limite
- Presión de trabajo: 0,5 bar*
- Para gases de la 2ª y 3ª familia, presión máxima de trabajo MOP 0,5 bar.

TECHNICAL CHARACTERISTICS

- Inner S.S. coarrugated hose, with braid and green PVC cover. S.S. 304 tube with S.S. braid and green PVC cover.
- S.S. 304 neck and S.S. 304 nut
- NBR gasket for the 1/2 female.
- Outer diameter: 20 mm
- Inner diameter: 12 mm
- Fitting inner diameter: 8 mm
- Flow rate: >0,8m³/h
- Minimum bending radius: no limite
- Working pressure: 0,5 bar*
- For uns with gas of 2nd and 3rd families, maximum working pressure MOP 0,5 bar.

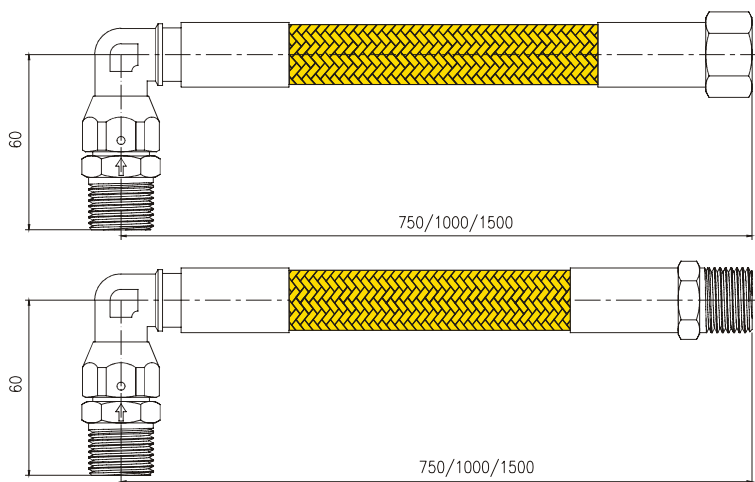
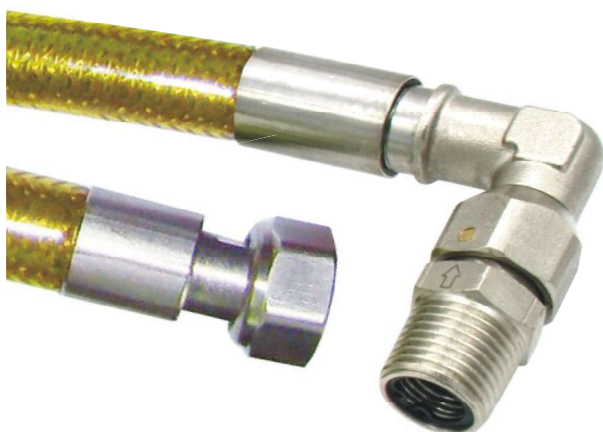

M1/2	SV12	H1/2	SV12	H1/2	H1/2
75 cm	1575M12SV12	40.48€	75 cm	1575H12SV12	40.48€
100 cm	15100M12SV12	44.72€	100 cm	15100H12SV12	44.72€
150 cm	15150M12SV12	53.26€	150 cm	15150H12SV12	53.26€
			75 cm	1575F12F12	25.43€
			100 cm	15100F12F12	31.52€

RACORD CONECTOR



M-M1/2
M1212 1.25€



H-H1/2
F1212 1.25€

Ref. 28 Junta plana para conexiones

Rubber gasket for water connection



CARACTERÍSTICAS TÉCNICAS

- Junta especial para agua y gas.
- ### APLICACIONES
- Conexiones para agua y gas.

TECHNICAL CHARACTERISTICS

- Special rubber gasket for water and gas utilities

APPLICATIONS

- Water and Gas connections

28JP38	Junta plana 3/8	10 x 14,5 x 2	Bolsa 100 u.	0.04€
28JP12	Junta plana 1/2	12 x 18,5 x 2	Bolsa 100 u.	0.04€
28JP34	Junta plana 3/4	18 x 24 x 2	Bolsa 100 u.	0.07€
28JP1	Junta plana 1"	23 x 30,5 x 2,2	Bolsa 100 u.	0.10€
28JP114	Junta plana 1" 1/4	27 x 38 x 3	Bolsa 50 u.	0.15€
28JP112	Junta plana 1" 1/2	33 x 44 x 3	Bolsa 50 u.	0.18€
28JP2	Junta plana 2"	42 x 56 x 3	Bolsa 50 u.	0.26€

Ref. 07/09 Reguladores de chorro para grifería

Jet regulators for sanitary ware / Brises jet pour robinetterie

Quality Standards EN 248 and 246



18/100 CROMO
20/100 CROMO
24/100 CROMO

MALE / ROSCA EXTERIOR

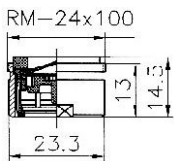

10 u./Box

0724C - 15 l/min. 24/100	0.90€
0724CBLI - 15 l/min. 24/100	1.05€
0720C - 12 l/min. 20/100	1.10€
0718MC - 12 l/min. 18/100	1.10€

16/100 CROMO
18/100 CROMO
22/100 CROMO

FEMALE / ROSCA INTERIOR

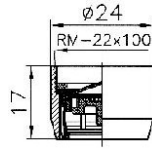

10 u./Box

0722C - 15 l/min. 24/100	0.97€
0722CBLI - 15 l/min. 22/100	1.10€
0718C - 12 l/min. 18/100	1.10€
0716C - 6 l/min. 16/100	1.10€

28/100 CROMO

MALE / ROSCA EXTERIOR

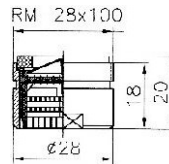

10 u./Box

0728C - 22 l/min. 22/100	1.40€
0728CBLI - 22 l/min. 22/100	1.55€

NOVA

22/100 CROMO
24/100 CROMO

MALE / ROSCA EXTERIOR
FEMALE / ROSCA INTERIOR

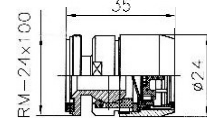

10 u./Box

0924NC Male - 15 l/min.	3.25€
0922NCH Female - 15 l/min.	3.25€

Ref. 10/12 ECONOMIZADORES WATER SAVING

24/100 CROMO

MALE / ROSCA EXTERIOR

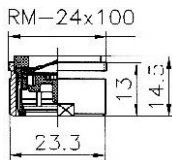

10 u./Box

1024C - 6 l/min. 24/100	0.90€
1024CBLI - 6 l/min. 24/100	1.05€

22/100 CROMO

FEMALE / ROSCA INTERIOR

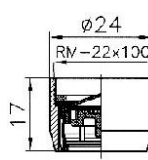

10 u./Box

1022C - 6 l/min. 22/100	0.97€
1022CBLI - 6 l/min. 22/100	1.10€

REGULADOR 1/2



10 u./Box

1028C 1/2 - 9 l/min.	1.90€
1028CBLI 1/2 - 9 l/min.	2.05€

Rociador con flexo OZ



120ZFLBOX - 6 l/min. 6.30€

Rociador OZ



120ZBOX - 6 l/min. 3.98€

Rociador RODAM



12RODAMBLI - 6 l/min. 2.75€

Applus⁺

Expediente 08/32306935 de 18.04.08
Correspondiente a Reguladores de chorro según: UNE-EN 246



Garantía de calidad ambiental

Regulador con flexo



112422CBLI - 6 l/min. 5.75€

Aireador con rótula

2 posiciones Universal



09UNI 6.75€

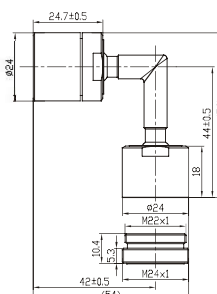

Llave regulador



07TOOL 0.60€

Ref. 11 Flexos de ducha ACERO INOX.

Stainless steel shower hoses / Flexibles de douche

APPLICABLE STANDARDS REFERENCE UNE-EN 1113

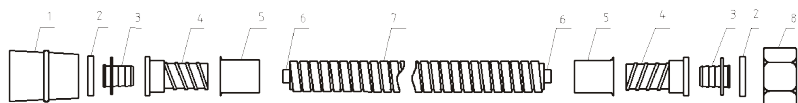

1- Brass nut with oring 2- Gasket 3- Brass insert 4- Plastic insert 5- Stainless Steel bell
6- EPDM inner tube 7- SS hose 8- Brass nut



High quality

Breaking pressure >50 bar

Traction >60 Bar

Technical specifications for shower hoses	Inner Ø	Outer Ø	Max. temp.	Working temp.	Operating press.	Traction resist.	Curvature radius	Nominal flow
Extensible Double Lock S.S.	8 mm	15 mm	110 °C	70 °C	50 Bar	0,6 Kn	45 mm	30 l/min
Double Lock S.S.	8 mm	15 mm	110 °C	70 °C	50 Bar	0,6 Kn	45 mm	30 l/min

EXTENSIBLE STAINLESS STEEL SHOWER HOSES



11151512BAG	Flexo para extraible M15/100xH1/2	1,5 m	6.10€
1115AE38BAG	Flexo para extraible M3/8xH1/2	1,5 m	6.10€
11151238BAG	Flexo Extensible para extraible Cónica H1/2xHexagonal H3/8	1,5 - 2,0 m	6.10€



1110SCBAG	Flexo extensible Acero Inox. doble grapado	Ext. 0,8 - 1 m	4.75€
1112SCBAG	Flexo extensible Acero Inox. doble grapado	Ext. 1 - 1,5 m	5.25€
1117AEBAG	Flexo extensible Acero Inox. doble grapado	Ext. 1,7 - 2,2 m	6.00€



1117AEBAG	Flexo ACERO INOX. exten. doble grapado	Ext. 1,7 - 2,2 m	7.20€
-----------	--	------------------	-------

STAINLESS STEEL SHOWER HOSES



1115CCBAG	Flexo Acero Inox. doble grapado	1,5 m	6.30€
1117CCBAG	Flexo Acero Inox. doble grapado	1,7 m	6.75€



1117BRBAG	Flexo Acero Inox. doble grapado Bronze	1,7 m	14.00€
-----------	---	-------	--------



1117COBAG	Flexo Acero Inox. doble grapado Copper	1,7 m	14.00€
-----------	---	-------	--------



1112INOXGBAG	Flexo Acero Inox. doble grapado Gold	1,2 m	8.00€
1117ORBAG	Flexo Acero Inox. doble grapado Gold	1,7 m	14.00€



1112INOXMBBAG	Flexo Acero Inox. doble grapado Black	1,2 m	10.00€
1115INOXMBBAG	Flexo Acero Inox. doble grapado Black	1,5 m	11.25€

Ref. 11 Flexos de ducha PVC LINE

Made in European Union



LINE PVC Shower hoses / Flexibles douche PVC LINE

APPLICABLE STANDARDS REFERENCE EN 1113

Flexos de ducha de PVC, que cumplen las más exigentes normas de calidad **EN 1113 - ACS - KTW**, en cuanto a su composición y características mecánicas. Ligeros muy resistentes y con una imagen actual. Muy recomendables para un uso intensivo y en zonas de costa.

CARACTERÍSTICAS TÉCNICAS - LINE

■ Flexible de ducha de plástico con hilos de Poliéster (hilos cruzados), 5-capas, acabado: liso - mate o brillo. 8,5 x 15 mm.

APLICACIONES

■ Griferías sanitarias.

PVC Shower Hoses, which fulfil the most demanding quality standards EN 1113 ACS-KTW, regarding its composition and mechanical characteristics. Light, very resistant and with a up-to-date look. Highly recommended for intensive usage and for coastal areas.

TECHNICAL CHARACTERISTICS - LINE

■ Flexible plastic shower hose with Polyester threads (crossed threads), 5-coats and plain, matt or gloss finish. 8,5 x 15mm.

APPLICATIONS

■ Sanitary Ware

Flexibles de douche PVC qu'accomplissent les réglementations plus exigentes de qualité EN 113 - ACS - KTW, en attendant sa composition et specifications mecaniques Légeres, très résistantes et avec une image actuel. Très Recommandables pour usages intensives et en zones costieres

SPÉCIFICATIONS TECHNIQUES - LINE

■ Flexible douche en plastique avec fils en Polyester (fils croisés), cruzados), 5-capas, acabado: liso - mate o brillo. 8,5 x 15 mm. 5 couches, finition: lisse, mat ou brillant. 8,5 x 15 mm.

APPLICATIONS

■ Robinetterie Sanitaire

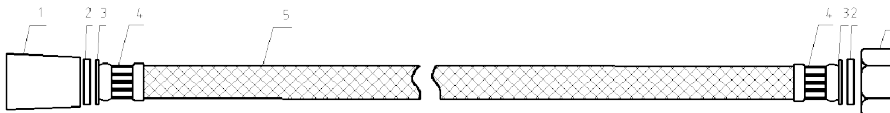

1- Brass nut 2- Rubber 3- Brass insert 4- Stainless Steel 201 bell 1000 5- PVC hose 6- Small brass nut

High quality
Breaking pressure >50 bar
Traction >60 Bar

Technical specifications for shower hoses	Inner Ø	Outer Ø	Max. temp.	Working temp.	Operating press.	Traction resist.	Curvature radius	Nominal flow
PVC Shower Hose with Polyester Threads	8 mm	15 mm	110 °C	70 °C	50 Bar	0,6 Kn	45 mm	30 l/min



CROMO / SILVER

1,2 m 1112LIRBAG 6.90€
1,7 m 1117LIRBAG 7.90€
0,8 m 1108LIRBAG 7.50€



NEGRO / BLACK

1,2 m 1112LMBBAG 8.90€
1,7 m 1117LMBBAG 10.10€
0,8 m 1108LMBBAG 7.50€



Bolsa expositor



BLANCO / WHITE

1,2 m 1112LMWBAG 8.90€
1,7 m 1117LMWBAG 10.10€



ORO / GOLD

1,2 m 1112LMGBAG 8.90€
1,7 m 1117LMGBAG 10.10€
0,8 m 1108LMGBAG 7.50€

DUBAI WATER SAVING (Flow rate 8 l/min) - ECONOMIZADOR



12DUBOX 19.05€



12DUMBBOX 19.05€

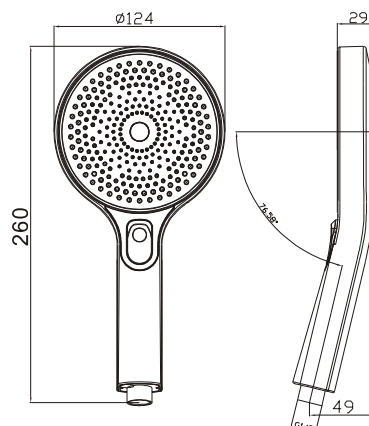

3 functions



258 NOZZLES

Spray, denso y suave
Silky and dense spray

Ref. 12 Rociadores

Suministro / Supply
Caja/box 10 u.

Sprinkle / Pommeaux de douche

APPLICABLE STANDARDS REFERENCE UNE-EN 1112

Roma



Color Box
12RRO 11.45€

Redondo Dalí

Diámetro 200 / 250 mm



200/250 mm

Color Box
12RD Ø200 mm 16.10€
12RD25 Ø250 mm 25.70€

Redondo Dalí negro



200 mm

Color Box
12RDDB Ø200 mm 17.00€

Cuadrado Miró

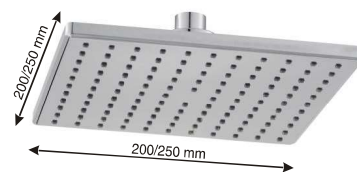

200/250 mm

Color Box
12RM 200x200 mm 17.60€
12RM25 250x250 mm 33.50€

AHORRO DE AGUA WATER SAVING

Applus⁺

Expediente 08/32306935 de 18.04.08
Correspondiente a Reguladores
de chorro según: UNE-EN 246



NANTES



12NABAG - 9 l/min. 4.20€
12NABOX - 9 l/min. 5.95€

DALÍ



12DABAG - 9 l/min. 4.20€
12DABOX - 9 l/min. 5.50€

GABÓN



12GABAG - 9 l/min. 6.50€
12GABOX - 9 l/min. 7.80€

Toma de agua cilíndrica con soporte, cromo Cylindrical water intake with support, Chrome



14ROME 18.20€

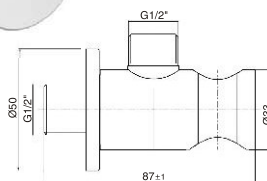

Bolsa Cisterna

Introduce la bolsa, con agua salada, en la cisterna y ahorra hasta 2 litros de agua en cada uso.

Introduce the bag, with salted water, inside the cistern and save up to 2 litres of water each time you use it.

Mettez-vous la boîte avec de l'eau salé dans la chasse d'eau et économisez-vous jusqu'au 2 litres d'eau par usage.



10BW 1.10€

Ducha ZEN

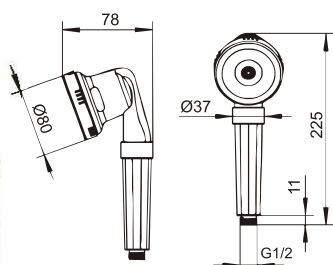

Bag
12ZENBOX 7.30€

- Ducha de mano de alta presión.
- Cuerpo de POLICARBONATO (PC).
- El cabezal es extraíble y lavable.
- Piedra natural en el interior.
- Reduce la cal, metales duros y bacterias del agua.
- Produce efecto zen.

- High pressure hand shower,
- POLICARBONATE (PC) body,
- ABS head and TPR anti-lime with three functions.
- The head is removable and washable.
- Natural stone inside. Mineralized.
- Reduces lime, hard metals, water bacteria.
- It produces zen effect.

Recambio piedra natural

(100 gr white+gray +red stone)



Bag
STONES 0.85€

Ref. 12 Duchas Ref. 16 Set ducha

Handshower / Douchettes à main

APPLICABLE STANDARDS REFERENCE UNE-EN 1112-1113

Suministro / Supply

Blister: 10 u. / Box: 10 u.

Ducha APEL



Set ducha APEL



Ducha DELHI latón/brass

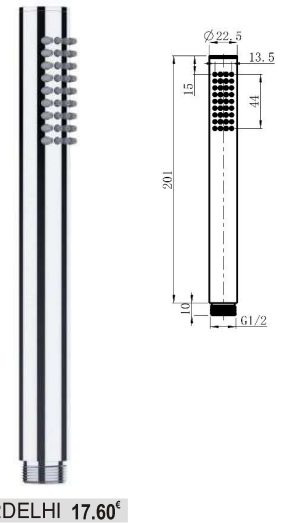

Ducha REX

extraible cocina



Ducha TECNO

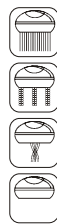

Cambio de posición automático



Ducha NIL



Ducha LEÓN

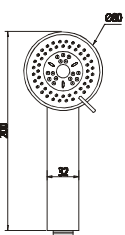

Set ducha LEÓN



Ref. 12 Duchas Ref. 16 Set ducha Ref. 17 Kit ducha

Handshower / Douchettes à main

APPLICABLE STANDARDS REFERENCE UNE-EN 1112-1113

Suministro / Supply

Blister: 10 u. / Box: 10 u.

Ducha ALTEA



Bag
12ATBAG 8.95€
12ATBOX 9.95€

Set ducha ALTEA



Ref. 1117AEBAG



Ref. 14SKYBAG

16ATBOX 18.90€

Kit ducha ALTEA



17ATBOX 33.00€

Ducha LIMA



Bag
12LIBAG 5.50€
12LIBOX 6.80€

12LIMBBAG 6.70€

Set ducha LIMA



Ref. 1117AEBAG



Ref. 14SKYBAG

16LIBOX 17.00€

Kit ducha LIMA



17LIBOX 31.50€

Ref. 14/17 Kits, barras y soportes de ducha

Kits, sliding bars and supports / Kits barre de douche et supports

Barra Luxe



Bag
14BLBAG 16.00€
14BLBOX 18.00€

Barra Onda



Bag
14ODBG 24.90€

Barra Moon



Bag
14MOONBAG 17.50€
14MOONMBBAG 17.50€

Barra Sau

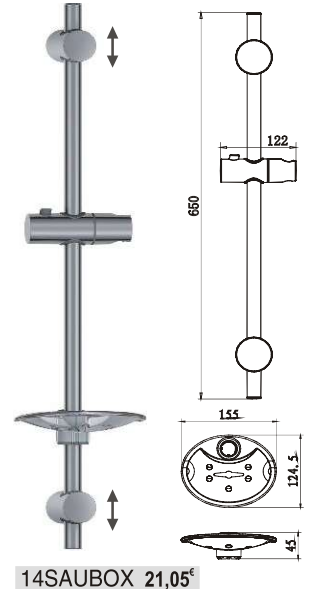

14SAUBOX 21.05€

Soporte Star

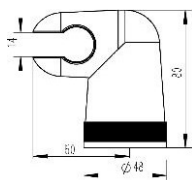

Bag
14SCBAG 2.75€

Soporte Sun

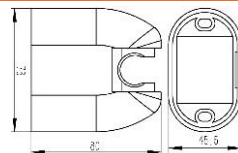

Bag
14SUNBAG 4.10€

Soporte Sky

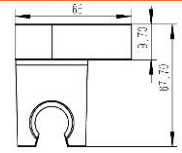

Bag
14SKYBAG 2.85€
14SKYMBBAG 2.90€

Ref. 16 Sets bidé (ducha-soporte-flexo) **APPLICABLE STANDARDS REFERENCE EN 1112-1113**

Shower kit (Handshower - support - shower hose)
Kits douche (douchette à main – support – flexible douche)

Suministro / Supply

Box: 15 u.

Elan blanco *white / blanche*

Elan cromo *chrome / chromé*



Kiel



Pisa blanco *white / blanche*

Pisa cromo *chrome / chromé*



Vich *chrome/chromé*

Vich *black/noir*

Vich *gold/or*



Lazio *chrome/chromé*

Lazio *black/noir*

Lazio *gold/or*



Ref. 19 Monomando con cartucho cerámico

Mixer with ceramic cartridge / Mitigeur avec cartouche ceramique

Suministro / Supply

Caja expo. / box 10 u.

CARACTERÍSTICAS TÉCNICAS

- Monomando de latón cromado
- Cartucho cerámico
- Florón de latón cromado

TECHNICAL CHARACTERISTICS

- Chrome-plated brass mixer
- Ceramic mixer cartridges
- Chrome-plated brass cover

SPÉCIFICATIONS TECHNIQUES

- Robinet mitigeur en laiton chromé
- Cartouche ceramique
- Rosace en laiton chromé

Colores disponibles / Available colors

- Silver ● Gold ● Black ○ White

Monomando VICH



Color box
19VICH 60.00€

Monomando VICH Negro



Color box
19VICHMB 65.00€

Monomando VICH Oro

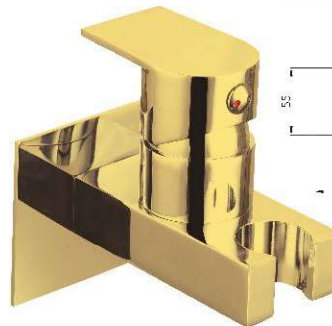

Color box
19VICHG 65.00€

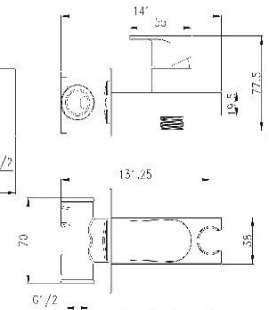

Monomando LAZIO



Color box
19LAZIO 60.00€

Monomando LAZIO Negro



Color box
19LAZIOMB 65.00€

Monomando LAZIO Oro



Color box
19LAZIOG 65.00€

- | | | |
|-------------------------|---------------------------|--------------------|
| 1 Plastic | 7 SS304 Stainless steel | 13 Stainless steel |
| 2 M4*25 Stainless steel | 8 H59-1 Brass | 14 Plastic |
| 3 H59-1 Brass | 9 Ø25mm Ceramic cartridge | 15 NBR |
| 4 NBR | 10 H59-1 Brass | 16 Brass |
| 5 NBR | 11 H62 brass | 17 Stainless steel |
| 6 NBR | 12 Zinc Alloy | |

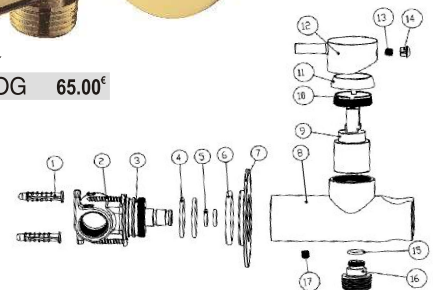

Monomando Prodec

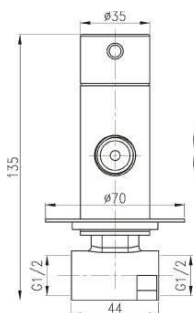

Color box
19MP12 40.00€

SETS MONOMANDO



Set Monomando
LAZIO



Set Monomando
VICH

- | | | |
|----------|--|---------|
| CHROME ○ | 32LAZIO (19LAZIO + 12LAZIO + 1112SC) | 87.50€ |
| BLACK ● | 32LAZIOMB (19LAZIOMB + 12LAZIOMB + 1112INOXMB) | 97.50€ |
| CHROME ○ | 32VICH (19VICH + 12VICHI + 1112SC) | 89.50€ |
| BLACK ● | 32VICHMB (19VICHMB + 12LAZIOMB + 1112INOXMB) | 99.50€ |
| GOLD ● | 32LAZIOG (19LAZIOG + 12LAZIOG + 1112INOXG) | 99.75€ |
| GOLD ● | 32VICHG (19VICHG + 12LAZIOG + 1112INOXG) | 101.75€ |

Ref. 19 Llaves de escuadra

APPLICABLE STANDARDS REFERENCE UNE 19703

Angle valves / Robinets d'arrêt d'équerre

Suministro / Supply
Caja expo. / box 50 / 100 u.

Colores disponibles / Available colors
● Silver ● Black ○ White



ZUG

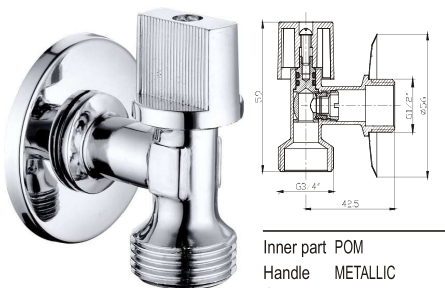

Inner part POM
Handle METALLIC
O-ring NBR
Body BRASS
Rosette STAINLESS STEEL
Weight 125 gr

1/2 x 3/4 1934Z 4.90€

Prodec 1

Cromo



Negro



Oro

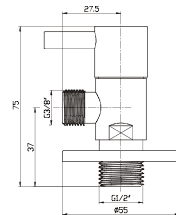

Inner part CERAMIC CARTRIDGE
Handle METALLIC
O-ring NBR
Body BRASS
Rosette STAINLESS STEEL
Weight 135 gr

1/2 x 3/8 1938P1 7.25€
1/2 x 1/2 1912P1 7.25€

1/2 x 3/8 1938P1MB 12.00€
1/2 x 1/2 1912P1MB 12.00€

1/2 x 3/8 1938P1G 12.00€
1/2 x 1/2 1912P1G 12.00€

Tor

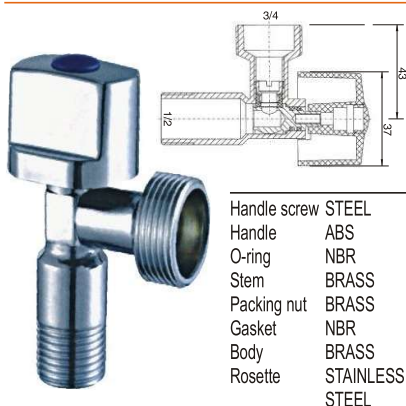

Handle screw STEEL
Handle ABS
O-ring NBR
Stem BRASS
Packing nut BRASS
Gasket NBR
Body BRASS
Rosette STAINLESS STEEL

1/2 x 3/4 1934T 4.50€ Weight 102 gr

Kali

Cromo



Negro



Oro

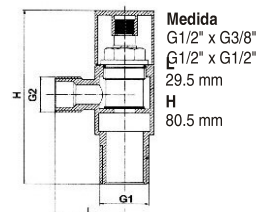
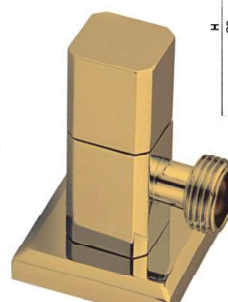

Inner part CERAMIC CARTRIDGE
Handle METALLIC
O-ring NBR
Body BRASS
Rosette STAINLESS STEEL
Weight 167 gr

1/2 x 3/8 19KALI38 7.60€
1/2 x 1/2 19KALI12 7.60€

1/2 x 3/8 19KALI38MB 12.50€
1/2 x 1/2 19KALI12MB 12.50€

1/2 x 3/8 19KALI38G 12.50€
1/2 x 1/2 19KALI12G 12.50€

Quatro

Cromo



Negro



Oro



1/2 x 3/8 1938Q 8.40€
1/2 x 1/2 1912Q 8.40€

1/2 x 3/8 1938QMB 12.50€
1/2 x 1/2 1912QMB 12.50€

1/2 x 3/8 1938QG 12.50€
1/2 x 1/2 1912QG 12.50€

Prodec 3



Inner part CERAMIC CARTRIDGE
Handle METALLIC
O-ring NBR
Body BRASS
Rosette STAINLESS STEEL
Weight 310 gr

G1/2x G3/8xG1/2
19PRO3 16.50€
BLACK ● 19PRO3MB 18.20€

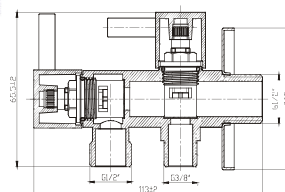

Bristol

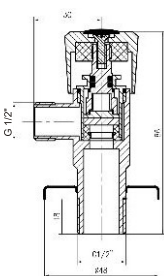

ACERO INOX. AISI 304
SS 304 ANGLE VALVE

1938SS 1/2 x 3/8 7.00€
1912SS 1/2 x 1/2 7.00€

Inner part CERAMIC CARTRIDGE
Handle METALLIC
O-ring NBR
Body STAINLESS STEEL
Rosette STAINLESS STEEL
Weight 160 gr

Milan ANTICAL-ANTILIME

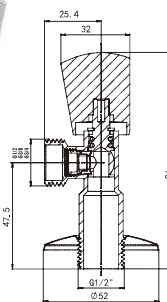

Handle ABS
O-ring NBR
Stem POM
Packing nut BRASS
Gasket NBR
Body BRASS
Rosette STAINLESS STEEL

Weight 152 gr

1/2 x 3/8 19MILAN38A 3.70€
1/2 x 1/2 19MILAN12A 3.70€

Ref. 19 Llaves de escuadra

APPLICABLE STANDARDS REFERENCE UNE 19703

Angle valves / Robinets d'arrêt d'équerre

Star

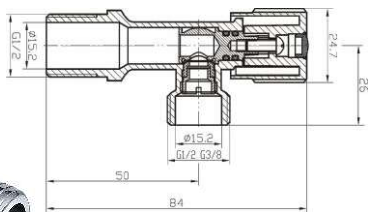

Handle screw	STEEL
Handle	METALLIC
O-ring	NBR
Stem	BRASS
Packing nut	BRASS
Gasket	NBR
Body	BRASS
Rosette	STAINLESS STEEL
Weight	120 gr

1/2 x 1/2 1912S 4.75€
1/2 x 3/8 1938S 4.75€

Seté Con filtro With filter

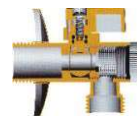

Cuerpo latón.
Mando metálico.
Peso: 107 gr
Brass body. Metallic handle SS cover.
Weight: 107 gr

Handle screw	STEEL
Handle	METALLIC
O-ring	NBR
Stem	BRASS
Packing nut	BRASS
Gasket	NBR
Body	BRASS
Rosette	STAINLESS STEEL
Weight	107 gr

1/2 x 1/2 19SETE12 5.25€
1/2 x 3/8 19SETE38 5.25€

Prodec 2

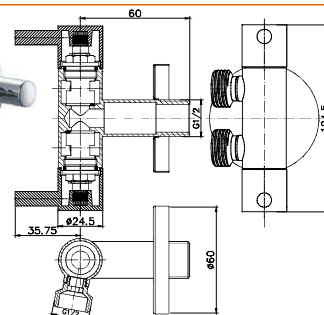

Inner part	CERAMIC CARTRIDGE
Handle	METALLIC
O-ring	NBR
Body	BRASS / STAINLESS STEEL
Rosette	STAINLESS STEEL
Weight	307 gr

LATÓN / BRASS
1/2x1/2x1/2
19PRO2 17.15€

Prodec 2 SS



ACERO / SS
1/2x1/2x1/2
19PRO2SS 12.00€

ACERO / SS / BLACK
1/2x1/2x3/8
19PRO2SSMB 14.00€

Nimes larga

ANTICAL-ANTILIME

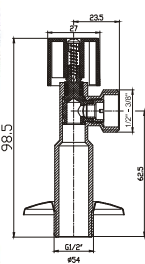

1/2 x 1/2 1912LA 3.95€
1/2 x 3/8 1938LA 3.95€

Nimes corta

ANTICAL-ANTILIME

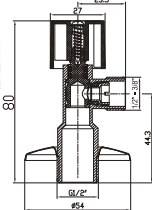

1/2 x 1/2 1912A 3.20€
1/2 x 3/8 1938A 3.20€
Weight 80 gr

Handle screw	STEEL
Handle	ABS
O-ring	NBR
Stem	POM
Packing nut	BRASS
Gasket	NBR
Body	BRASS
Rosette	S.S.
Weight	80 gr

Llave doble lavavajillas

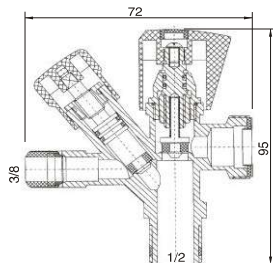
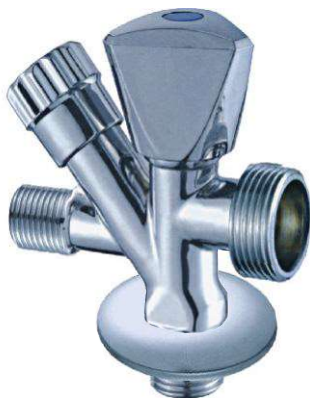

1/2 x 3/4 x 3/8 193438 12.40€
1/2 x 1/2 x 3/8 191238 12.40€

Handle screw	STEEL
Handle	ABS
O-ring	NBR
Stem	BRASS
Packing nut	BRASS
Gasket	NBR
Body	BRASS
Rosette	STAINLESS STEEL
Weight	219 gr

Prodec Antical-Antilime

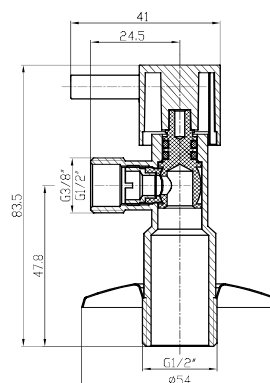

1/2 x 3/8 1938P1A 5.00€
1/2 x 1/2 1912P1A 5.00€

Ref. 20 Grifos lavadora

Washing machine taps / Robinets machine à laver

APPLICABLE STANDARDS REFERENCE UNE 19703

CARACTERÍSTICAS TÉCNICAS

■ Grifo de 1/2 x 3/4, latón cromado, monturas de 1/4.

TECHNICAL CHARACTERISTICS

■ Chrome-plated tap 1/2 x 3/4 1/4 fittings.

SPÉCIFICATIONS TECHNIQUES

■ Robinet 1/2 x 3/4, laiton chromé, têtes 1/4".

Grifo lavadora



Blister
20GL34BOX 7.90€

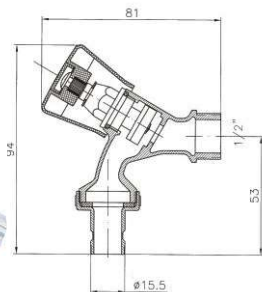

Suministro / Supply
Blister: Caja/box 50 u.

Grifo lavadora doble



Blister
20GL34DBOX 13.70€

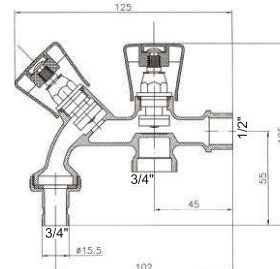

Suministro / Supply
Caja/box 50 u.

Ref. 18 Válvula y grifo de esfera

Brass ball valve / bibcock / Soupape et robinet à sphere

APPLICABLE STANDARDS REFERENCE EN 1113

CARACTERÍSTICAS TÉCNICAS

■ Válvula y grifo con cuerpo de latón.
■ Maneta acero inoxidable cromado.
■ Tuerca de latón
■ Bola latón/acero

TECHNICAL CHARACTERISTICS

■ Brass valve and brass tap body.
■ Chrome-plated stainless steel handle.
■ Brass nut
■ Brass/steel ball

SPÉCIFICATIONS TECHNIQUES

■ Soupape et robinet corps en laiton
■ Manette en acier inoxydable chromé
■ Écrou laiton
■ Boule laiton / acier

Grifo esfera jardín

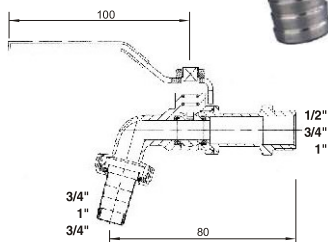

1/2 x 3/4 - Grifo esfera jardín 181234 5.05€
Caja / box 15 u. - Peso / Weight 170 gr

3/4 x 1" - Grifo esfera jardín 18341 8.00€
Caja / box 10 u.

Grifo esfera jardín 2 Salidas

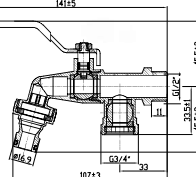

Grifo esfera jardín 2 salidas
Brass bibcock with two outputs

1/2 x 3/4x3/4 18123434 11.70€
Caja / box 10 u. - Peso / Weight 200 gr

Válvula esfera

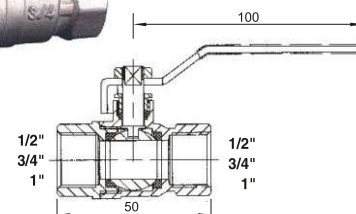

H-H 1/2" - Válvula esfera 1812 5.10€
Caja / box 12 u. - Peso / Weight 152 gr

H-H 3/4" - Válvula esfera 1834 6.90€
Caja / box 10 u.

H-H 1" - Válvula esfera 1811 11.30€
Caja / box 10 u.



1/2 x 1/2 - Grifo jardín
18ZETA 13.65€

GRIFO JARDIN (montura cerámica)

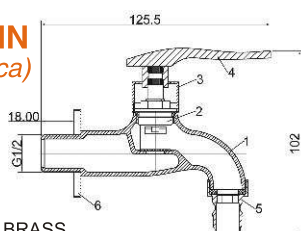

- 1 - BODY - BRASS
- 2 - CARTRIDGE - BRASS+CERAMICS
- 3 - CONNECT - ZINC
- 4 - HANDLE - ZINC
- 5 - OUTPUT - INOX
- 6 - COVER - INOX

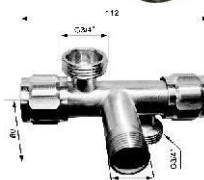

PRODEC34SS

Válvula de acero inoxidable 304 con cartucho latón cerámico
SS 304 Angle valve with brass cartridge
1/2x3/4x3/4
Acero / SS

19PRO34SS 15.10€

Ref. 27 Sifones lavabo *Basin siphon / Siphon lavabo laiton*

APPLICABLE STANDARDS REFERENCE UN274-1

Luxe



Cromo
27LUXE 33.80€



Negro
27LUXEMB 39.00€



Oro
27LUXEG 43.20€



Latón viejo - Bronce
27LUXEBR 46.00€

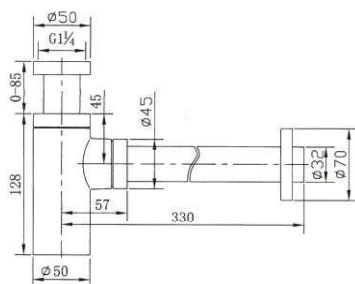

Cuatro



Cromo
27CUATRO 39.75€



Negro
27CUATROMB 46.40€



Oro
27CUATROG 48.30€

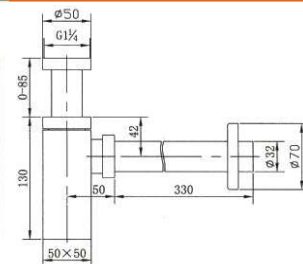

Ito



27ITO 18.60€

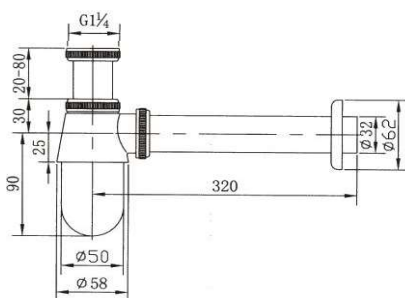

Adaptador

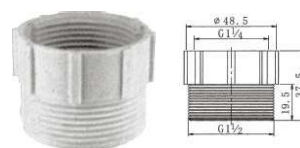

1 1/4 - 1 1/2
Bag
26AD112 0.80€

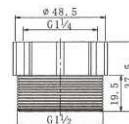

Ref. 26 Click-clack desagüe universal

Brass automatic pop-up waste drainers
Vidages clic clac laiton

APPLICABLE STANDARDS REFERENCE UN274-1



Cuatro



Ares



Seoul

Con tapón desmontable, fácil limpieza y filtración eficiente.
With removable cap, easy cleaning and efficient filtration.

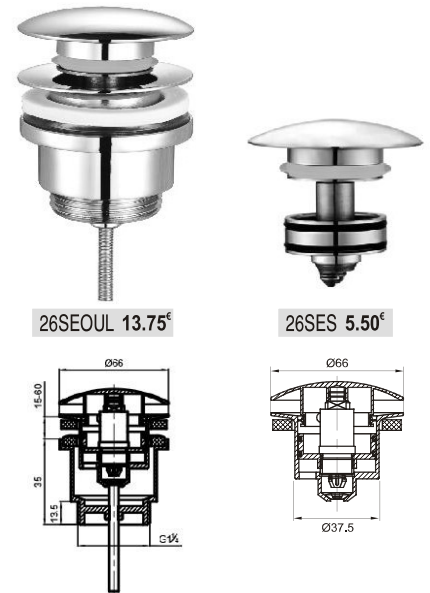

Luxe



Válvula universal

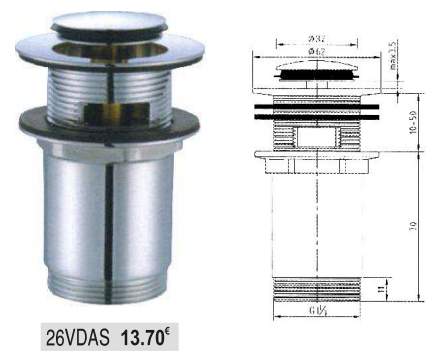

Válvula universal ABS



Aran



Kibo



Water tank flush valves and fill float valves
Chasse d'eau et robinet flotteur

Suministro / Supply
Box: 20 u. / Bag: 20 u.

Descargas WC doble pulsador

WC Water tank double flush push button
Chasse d'eau WC doublé à double poussoir

Valvula descarga con rosca universal y todos sus accesorios (juntas y fijaciones)

Flush valve with universal thread and all accessories (joints and assembling fittings)

Mechanisme chasse d'eau avec filetage universel et tous ses accessoires (joints et fixations)



Color Box
29DSUVA 18.50€

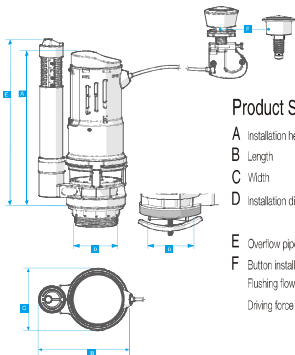

Product Specification

A	Installation height (include rubber)	208 mm
B	Length	119 mm
C	Width	83 mm
D	Installation diameter	For two-piece: 2NPSM / For one-piece: 64mm
E	Overflow pipe adjustment height	185-285mm
F	Button installation size	18 x 18mm / Diameter: 38.5mm
	Flushing flow	2.2 L/S
	Driving force	18 N (200mm water level)

Color Box
29DDPBOX 20.50€

Grifo flotador toma UNIVERSAL

UNIVERSAL Fill float valve
Robinet flotteur alimentation universel

- Fácil instalación.
- Easy to install.
- Facile installation
- Graduación de llenado a voluntad.
- Water load fill adjustable as desired.
- Graduación de rémplissage à volonté
- Rápido y silencioso.
- Fast and noiseless refill.
- Rapide et silencieux

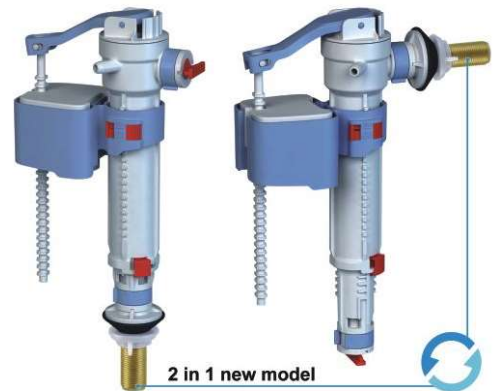

2 in 1 new model

Color Box
29GFBOX 9.50€

Grifo flotador lateral

Lateral fill float valve



Color Box
29GFLBOX 9.55€

Con filtro superior. Fácil de limpiar. Sin herramientas. Ideal!
Top filter, easy & non-tooling clean, super convenient



Llave Key
Filtro Filter



EXTRA SILENCIOSO!!
Sólo 15 DB (requisito de nivel 1 END de la UE)
Extra silence, 15DB, EU's END Level 1 requirement

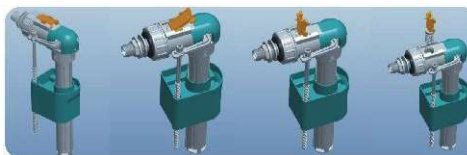

Diseño integrado en la llave y el filtro para evitar una posible pérdida de componentes. Fácil de usar. Filtro superior. Fácil de limpiar y sin herramientas. Ideal!
Integrated design on the key & filter, to avoid possible component missing, user friendly.

Tapa y aro para inodoro

Toilet seat cover Housse de siège toilette



Caja / box 10 u.
29TSC 18.00€

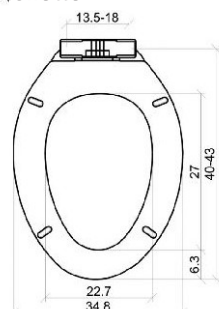

Caja / box 10 u.
29TSCSD 24.00€



Ref. 22 Soporte bañera / INOX / SS AISI 304

Safety grab bar / Poignee baignoire

Breda



Acero Inox. AISI 304 pulido
SS AISI 304 polished

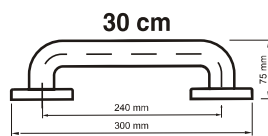

22B30BOX 20.75€

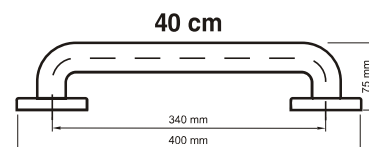

22B40BOX 22.60€

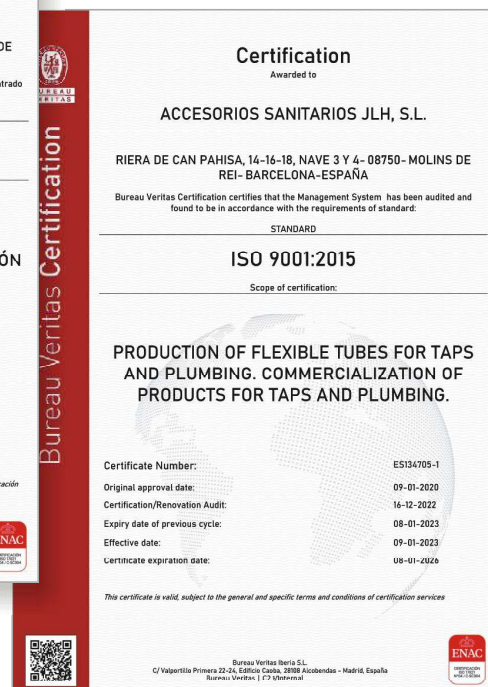

Condiciones generales de venta *General sales conditions*

CONSULTA Y PEDIDOS

Queries and orders
Tel. +34 93 666 71 51

PEDIDOS POR E-MAIL

E-mail orders
ventas@jlh-spain.com

ATENCIÓN AL CLIENTE

Customer support
atencionalcliente@jlh-spain.com

WEB

www.jlh-spain.com

DESCUENTOS / *Discounts / Reductions*

- Consultar con su agente o distribuidor.
- *Refer to agent or supplier*
- *Consultez votre revendeur*

FORMA DE PAGO / *Terms of payment / Modalités de paiement*

- Venta al contado o crédito mediante giro bancario.
- *Cash payment or credit payment through money order*
- *Comptant au á credit paiement para virement bancaire*

PORTES / *Portage charges / Fret*

- Pagados y sin coste adicional si el pedido es superior a 300 euros.
- *Portage free of charges and no additional costs to orders over 300 euros.*
- *Versée si l'ordre est plus de 300 euros*

DEVOLUCIONES

- Plazo de devolución: ampliamos a 15 días naturales
- El producto debe ser devuelto en perfecto estado con todos sus accesorios, instrucciones y embalaje.
- Los artículos devueltos incompletos, estropeados, dañados o deteriorados no serán aceptados.
- Los productos personalizados o manipulados no tienen posibilidad de cambio o devolución.
- En ningún caso, nos haremos responsables de la mala instalación o uso inadecuado del producto.
- No tire el embalaje original hasta el final del plazo.
- Antes de la devolución debe de informar a atencionalcliente@jlh-spain.com
- Deberá ser enviado en los siguientes 5 días laborables tras la aceptación de la devolución.
- Si la devolución es responsabilidad de Accesorios Sanitarios JLH SL y se encuentra en los 15 días naturales después de recibir el pedido, los portes serán pagados.
- El resto de devoluciones, los portes los pagara el cliente. Una vez valoradas y aceptada la devolución por parte de Accesorios Sanitarios JLH SL se decidirá sobre el importe a abonar.



www.jlh-spain.com

ACCESORIOS SANITARIOS JLH, S.L.

N.I.F. B-59.148.007

Tel. + 34 936 667 151

ventas@jlh-spain.com

www.jlh-spain.com